

TN-4500B Series Quick Installation Guide

Moxa ToughNet Managed Switch

Version 1.0, September 2024

Technical Support Contact Information
www.moxa.com/support

MOXA®

© 2024 Moxa Inc. All rights reserved.

P/N: 1802045003010



Overview

The ToughNet managed switch TN-4500B Series is designed for Ethernet networks in rolling-stock applications. The managed switches feature M12 interfaces to ensure tight, robust connections, and guarantee reliable operation in industrial environments where vibration and shock are commonplace. The TN-4500B Series consists of simple models with 8 Fast Ethernet ports to advanced models with 20 Fast Ethernet and 8 Gigabit ports (with optional 4 bypass relay). In addition, the PoE models provide up to 4 Gigabit Ethernet and up to 20 Fast Ethernet PoE output ports compliant with IEEE 802.3af/at standard.

The TN-4500B managed switches reference the IEC 62443-4-2 industrial cybersecurity standard and are designed to mitigate the risk of cyberattacks. They come with a wide power input range of 24 to 110 VDC to facilitate different applications across networks. The -40 to 70°C wide temperature range allows the switches to operate in demanding environmental conditions for extended periods of time. Furthermore, these switches comply with the mandatory requirements of EN 50155, making them suitable for a variety of industrial applications without requiring any maintenance.

NOTE When installed according to the Quick Installation Guide (QIG) and used under the conditions specified in the datasheet, Moxa products require no maintenance.

Package Checklist

Your ToughNet TN-4500B Series managed switch is shipped with the following items:

- TN-4500B Series managed switch
- Protective metal caps (male) for the M12 console port (x 1) and USB storage port (x 1), for the M12 Ethernet ports preinstalled (4/6/8/10/14 caps for TN-4508/12/16/20/28B models respectively).
- Wall-mounting kit (including 4 screws)
- Quick installation guide (printed)
- Warranty card

NOTE If any of these items are missing or damaged, please contact your customer service representative for assistance.

Panel Layouts

The diagrams here show the TN-4516B model. Interface combinations and numbers vary depending on the models in the series.

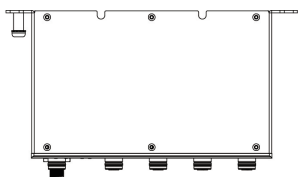

Top View

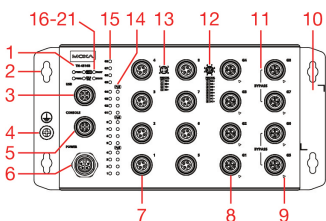

Front View

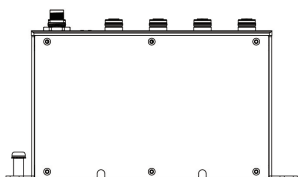

Bottom View

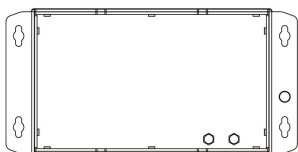

Rear View

1. Model name
2. Wall-mounting kit aperture (M4)
3. USB storage port (M12 A-coded 5-pin female connector)
4. Grounding screw (M6)
5. Serial console port (M12 B-coded 5-pin female connector)
6. Power connector (M12 K-coded 5-pin male connector)
7. Fast Ethernet port (M12 D-coded 4-pin female connectors for 10/100BaseT(X))
8. Gigabit Ethernet port (M12 X-coded 8-pin female connectors for 10/100/1000BaseT(X))
9. Alignment mark for X-coded connector
10. Model label
11. Indicators for bypass sets of connectors¹
12. Pin definition for M12 X-coded connectors²
13. Pin definition for M12 D-coded connectors
14. PoE port LEDs³
15. Ethernet port LEDs
16. PWR1 LED for power input 1
17. PWR2 LED for power input 2
18. CPLR/TAIL LED for ring coupler or chain tail
19. MSTR/HEAD LED for ring master or chain head
20. FAULT LED for fault event alert
21. STATE LED for system status

¹Applicable only for models with bypass-ports.

²Applicable only for models with GbE ports.

³Applicable only for models with PoE ports.

See "Port Layout and Indicators" for details.

Port Layout and Indicators

The TN-4500B Series models come with labels/indicators next to all ports including Gigabit Ethernet, PoE, and bypass ports. Ports are numbered from bottom to top and left to right. Depending on the model that you have purchased, the size and layout of the front panel will vary. Here we use the TN-4516B model as an example to explain the port layout.

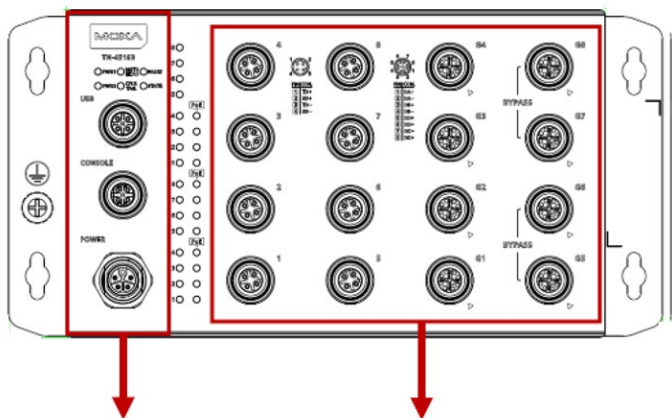

General Purpose Ports

Data Connection Ports

The ports are organized in two regions separated by the LED indicator area.

General Purpose Ports:

This part is the same for all models.

Data Connection Ports:

The number and type of ports differ for each model starting with 8 ports and can go up to 28 ports. Refer to the table below for a model-wise listing of ports.

G<n>: Gigabit Ethernet ports

<n>: Fast Ethernet ports

Model	Port No.	PoE Ports	Bypass Port Sets
TN-4508B-CT-T	1 to 8	N/A	N/A
TN-4512B-CT-T	1 to 12	N/A	N/A
TN-4512B-8P-4G-CT-T	1 to 8 G1 to G4	1 to 8	N/A
TN-4516B-CT-T	1 to 16	N/A	N/A
TN-4516B-8G-CT-T	1 to 8 G1 to G8	N/A	N/A
TN-4516B-8P-4G-4GP-CT-T	1 to 8 G1 to G8	1 to 8, G1 to G4	N/A
TN-4516B-8P-4GP-4GBP-CT-T	1 to 8 G1 to G8	1 to 8 G1 to G4	G5, G6 (Set 1) G7, G8 (Set 2)
TN-4520B-12P-4G-4GP-CT-T	1 to 12 G1 to G8	1 to 12 G1 to G4	N/A

Model	Port No.	PoE Ports	Bypass Port Sets
TN-4520B-12P-4GP-4GBP-CT-T	1 to 12 G1 to G8	1 to 12 G1 to G4	G5, G6 (Set 1) G7, G8 (Set 2)
TN-4528B-20P-4G-4GP-CT-T	1 to 20 G1 to G8	1 to 20 G1 to G4	N/A
TN-4528B-20P-4GP-4GBP-CT-T	1 to 20 G1 to G8	1 to 20 G1 to G4	G5, G6 (Set 1) G7, G8 (Set 2)

LED Indicators

Multiple LED indicators are located on the front panel of the TN-4500B managed switch. The function of each LED is described in the tables below:

Device LEDs

LED	Color	State	Description
PWR1/ PWR2	Amber	On	Power is supplied to power input PWR1/PWR2.
		Off	Power is off.
MSTR HEAD	Green	On	When the TN switch is the Master of the Turbo Ring or Root of RSTP.
		Blinking	The switch has become the Master of the Turbo Ring after the Turbo Ring has gone down. OR The switch is set as a member of the Turbo Ring but the corresponding ring port is down.
		Off	When the TN switch is not the Master of this Turbo Ring
CPLR TAIL	Green	On	Ring coupling is enabled in the TN switch
		Blinking	N/A
		Off	When ring coupling is disabled in the TN switch
FAULT	Red	On	Looping event has occurred OR The port is being disabled because it has exceeded the ingress rate limit of the shutdown mode OR External storage loading/saving failure
		Off	No looping event has occurred OR The system is running well after a boot up

LED	Color	State	Description
STATE	Green	On	The system passed the self-diagnosis test during bootup and is ready to run
		Blinking (1 Hz)	System service is initializing
		Blinking (4 Hz)	An external storage is connected to the switch
		Off	N/A
	Red	On	The system has initially failed the bootup process OR System info read fail/ EEPROM information error

Port LEDs

LED	Color	State	Description
FE Ports (10/100M for copper ports)	Amber	On	The port's 10 Mbps link is active.
		Blinking	Data is being transmitted at 10 Mbps.
		off	The port's 10 Mbps link is inactive.
	Green	On	The port's 100 Mbps link is active.
		Blinking	Data is being transmitted at 100 Mbps.
		off	The port's 100 Mbps link is inactive.
GE Ports (10/100/1000M, for copper ports)	Amber	On	The port's 10 or 100 Mbps link is active.
		Blinking	Data is being transmitted at 10 or 100 Mbps.
		Off	The port's 10 or 100 Mbps link is inactive.
	Green	On	The port's 1000 Mbps link is active.
		Blinking	Data is being transmitted at 1000 Mbps.
		Off	The port's 1000 Mbps link is inactive.
PoE Ports	Amber	On	Power is being supplied to a Powered Device (PD).
		Off	Power is not being supplied to a Powered Device (PD).

Dimensions

TN-4508B Models

Unit: mm (inch)

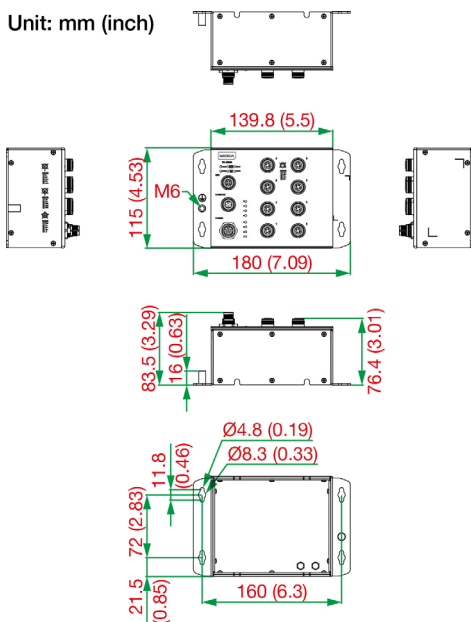

TN-4512B non-PoE Models

Unit: mm (inch)

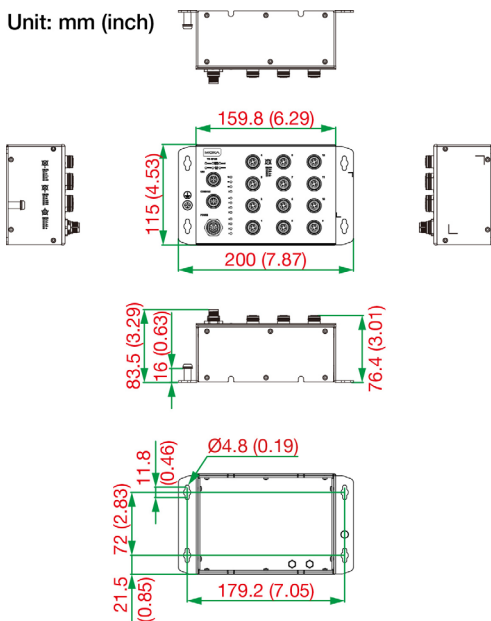

TN-4512B PoE Models

Unit: mm (inch)

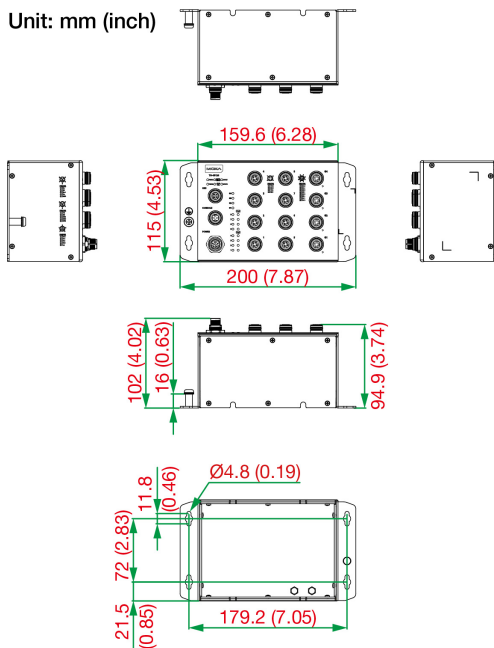

TN-4516B non-PoE Models

Unit: mm (inch)

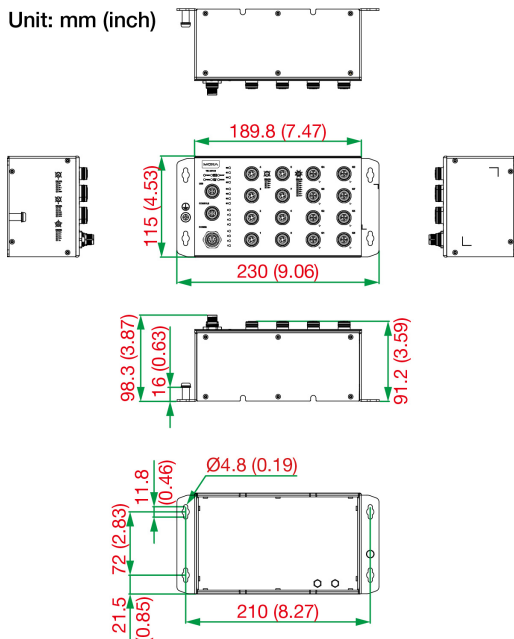

TN-4516B PoE Models

Unit: mm (inch)

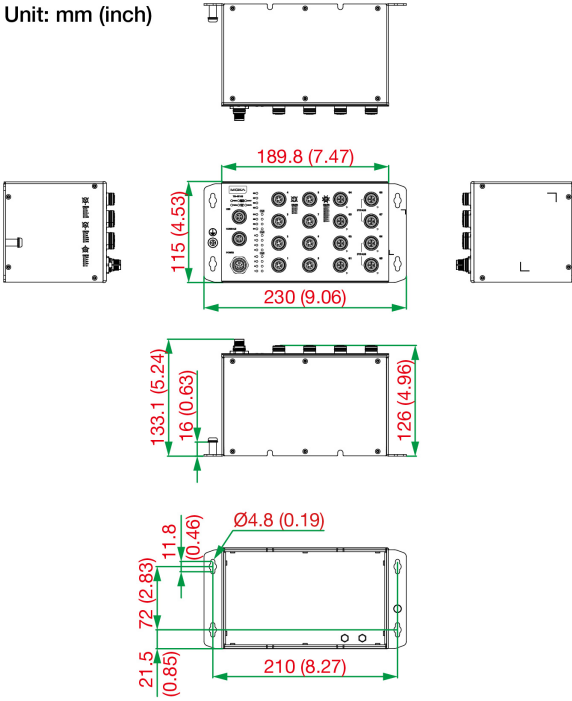

TN-4520B Models

Unit: mm (inch)

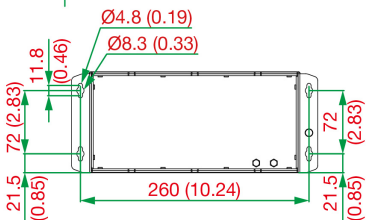
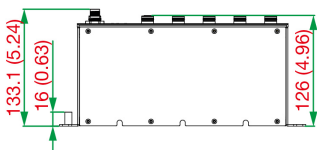
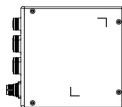
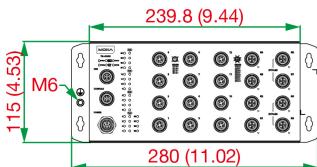
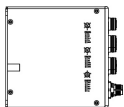
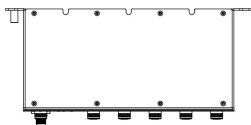

TN-4528B Models

Unit: mm (inch)

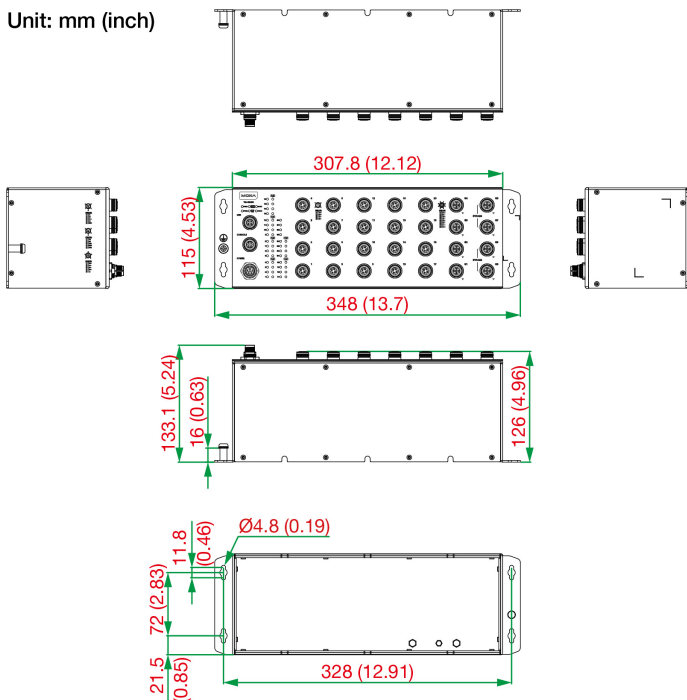

Wall Mounting

STEP 1: Mounting the TN-4500B to a wall requires 4 screws. Use the keyhole-shaped apertures of the switch as a guide to mark the positions of the 4 screws on the wall.

STEP 2: Use the 4 screws in the wall mounting kit and drive them into the wall at the points marked on the wall.

Do not drive the screws in all the way—leave a space of about 2 mm to allow room for sliding the switch between the wall and the screws.

If you would like to purchase the mounting screws separately, ensure that they are M4 x P 0.7 with length 10 mm as indicated in the illustration here

A torque value of 8 kgf-cm is recommended for the mounting screws.

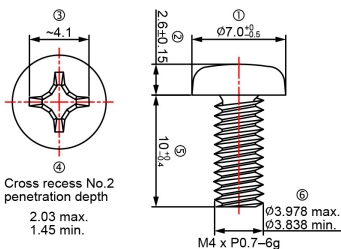

NOTE Before fixing the screws on to the wall, make sure the screw head and shaft size are suitable by inserting the screw through the keyhole-shaped apertures of the switch.

STEP 3: After fixing the mounting screws to the wall, align the screw holes of the keyhole-shaped apertures of the mounting kit with the screws and slide the switch up/down based on installation situation. Tighten the four screws for added stability.

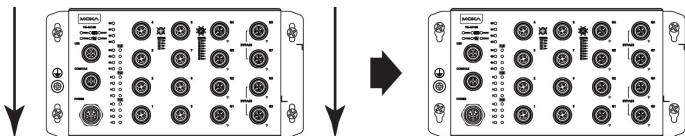

ATTENTION

This product is intended to be mounted to a well-grounded mounting surface such as a metal panel.



ATTENTION

Exposed connectors when not in use must be tightly covered with protective caps (an optional accessory) to ensure IP42-rated protection.

We recommend using the following connector caps:

- A-CAP-M12F-M-PP connector caps.

Wiring Requirements



WARNING

Turn the power off before disconnecting modules or wires. The correct power supply voltage is listed on the product label. Check the voltage of your power source to make sure you are using the correct voltage. Do NOT use a voltage greater than what is specified on the product label.



ATTENTION

Safety First!

Observe all electrical codes dictating the maximum current allowable for each wire size. If the current goes above the maximum ratings, the wiring could overheat, causing serious damage to your equipment.

Please Read and Follow These Guidelines

- Use separate paths to route wiring for power and devices. If power wiring and device wiring paths must cross, make sure the wires are perpendicular at the intersection point.

NOTE Do not run signal or communications wiring and power wiring through the same wire conduit. To avoid interference, wires with different signal characteristics should be routed separately.

- You can use the type of signal transmitted through a wire to determine which wires should be kept separate. The rule of thumb is that wiring that shares similar electrical characteristics can be bundled together.
- Keep input wiring and output wiring separated.
- It is strongly advised that you label wiring for all devices in the system when necessary.

Grounding the ToughNet Managed Switch

Grounding and wire routing help limit the effects of noise due to electromagnetic interference (EMI). Run the ground connection from the grounding screw to the grounding surface prior to connecting devices.

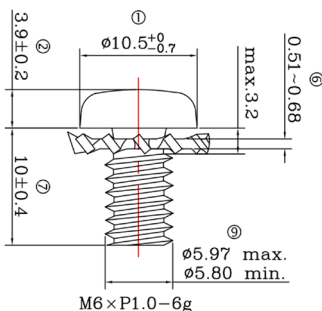
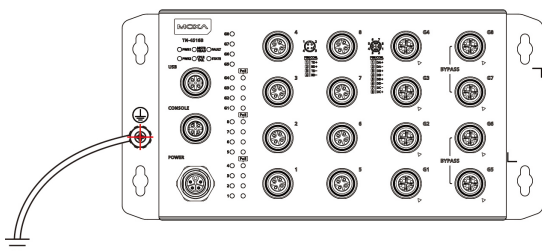

ATTENTION

To ground this product to the earth ground, use a green and yellow AWG 16 or higher grounding cable.

The grounding screw (M6 x P1.0, length 10 mm) comes fixed to the device. The recommended torque value for the screw is 10 kgf-cm.

Connecting the Power Supplies

The ToughNet TN-4500B Series managed switches support dual power inputs—power input 1 and power input 2. The M12 K-coded 5-pin male connector on the TN-4500B's front panel is used for the dual power inputs.

Pinouts for the Power Input Port

PIN	PWR
1	V1+
2	V1-
3	V2-
4	V2+
5	

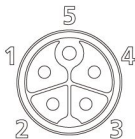

Pin	Description	Usage
1	PWR1 / DC +	Connect "PWR1 Live / DC +" to the positive (+) terminal when using a DC power source.
2	PWR1 / DC -	Connect "PWR1 Neutral / DC -" to the negative (-) terminal when using a DC power source.
3	PWR2 / DC -	Connect "PWR2 Neutral / DC -" to the negative (-) terminal when using a DC power source.
4	PWR2 / DC +	Connect "PWR2 Live / DC +" to the positive (+) terminal when using a DC power source.
5	Chassis Ground	Connect the "Chassis Ground" to the equipment ground bus for DC inputs.

STEP 1: Plug your power cord connector into the power input port of the TN-4500B managed switch.

STEP 2: Screw the nut on your power cord connector into the power input connector on the managed switch to ensure a tight connection.



ATTENTION

Before connecting the TN-4500B Series to the power input, make sure the power source voltage is stable. Do not power on the TN-4500B Series before connecting the M12 power connector.

NOTE The power cable CBL-M12KFF5POPEN-O-150-IP67 and the power connector M12K-5PFF-IP65-PxC is recommended. The diameter of the power cable should be AWG 14 or higher. The cable dimensions depend on the choice of pin number and type of M12 coding.



ATTENTION

This equipment is intended to be supplied by an external power source (UL listed/IEC 60950-1/IEC 62368-1). The TN-4500B Series requires an output rating of 24 to 110 VDC at an ambient temperature of min. 70°C.

The minimum current rating varies for the different TN-4500B Series models as listed below:

- 0.56 A (min.) for TN-4508B models
- 0.66 A (min.) for TN-4512B non-PoE models
- 0.83 A (min.) for TN-4516B non-PoE models
- 4.9 A (min.) for TN-4512B PoE models
- 9.3 A (min.) for TN-4516/20/28B PoE models

NOTE Inrush Current

TN-4508/12/16B non-PoE:

Peak= 3.7 A, 270 mA²s @ 24 VDC

Peak= 1.3 A, 38 mA²s @ 110 VDC

TN-4512B PoE:

Peak= 7.7 A, 640 mA²s @ 24 VDC

Peak= 7.5 A, 118 mA²s @ 110 VDC

TN-4516/20/28B PoE:

Peak= 11 A, 2.2 A²s @ 24 VDC

Peak= 13.4 A, 170 mA²s @ 110 VDC



ATTENTION

Restricted Access Location

This equipment is intended to be used in restricted access locations, such as control rooms. Access should be restricted to qualified service personnel or authorized users.

Isolated Power Inputs

The TN-4500B Series switches support an input voltage range of 24 to 110 VDC (continuous voltage input from 16.8 to 137.5 VDC as stated by EN 50155*)

*This product is suitable for rolling stock railway applications, as defined by the EN 50155 standard. For a more detailed statement, click here: www.moxa.com/doc/specs/EN_50155_Compliance.pdf.

Connecting the Data Lines

10/100BaseT(X) Ethernet Port Connection

The TN-4500B switches come with 4-pin shielded M12 D-coded connectors on the 10/100BaseT(X) Ethernet ports. These ports are located on the front panel and are used to connect to Ethernet-enabled devices. Most users configure these ports for Auto MDI/MDI-X mode, in which case the port's pinouts are adjusted automatically depending on the type of Ethernet cable used (straight-through or cross-over), and the type of device (NIC-type or HUB/Switch/Router-type) connected to the port.

NOTE The suggested cable for M12 D-coded-to-M12 D-coded connections is CBL-M12DMM4PM12DMM4P-BK-100-IP67. The suggested cable for M12 D-coded-to-RJ45 connections is CBL-M12D(MM4P)/RJ45-100 IP67.

The suggested connector is M12D-4P-IP68 (solder type). The suggested connector for metal shells is M12D-4PMM-IP67 (crimp type).

Pinouts for the 10/100BaseT(X) Ports

PIN	TX
1	TD+
2	RD+
3	TD-
4	RD-



Housing: shield

10/100/1000BaseT(X) Ethernet Port Connection

The TN-4500B switches come with 8-pin shielded M12 X-coded connectors on the 10/100/1000BaseT(X) Ethernet ports. These ports located on the front panel are used to connect to Ethernet-enabled devices. Most users configure these ports for Auto MDI/MDI-X mode, in which case the port's pinouts are adjusted automatically depending on the type of Ethernet cable used (straight-through or cross-over), and the type of device (NIC-type or HUB/Switch/Router-type) connected to the port.

Pinouts for the 10/100/1000BaseT(X) M12 (8-pin) Port

PIN	Con.
1	DA +
2	DA -
3	DB +
4	DB -
5	DD +
6	DD -
7	DC -
8	DC +



PoE Pinout	D-coded	X-coded
V+	Pin 1, 3 (TD+, TD-)	Pin 1, 2 (DA+, DA-)
V-	Pin 2, 4 (RD+, RD-)	Pin 3, 4 (DB+, DB-)

PoE Output Power for IEEE 802.3at/af Compliant PoE Ports

Output per port: 30 W

Total PoE Budget

TN-4512 PoE models: 80 W

TN-4516/20/28B PoE models : 150 W



ATTENTION

For PoE Models

For safety reasons, we do not recommend connecting this device to a network with routing to external networks.

NOTE The cable recommended for M12 X-coded-to-open wires is CBL-M12XMM8P-Y-100-IP67.

The cable recommended for M12 X-coded-to-RJ45 connections is CBL-M12XMM8PRJ45-Y-200-IP67.

The recommended connector is M12X-8PMM-IP67-HTG.



ATTENTION

Use a torque wrench to tighten the M12 connector/cable. The torque value recommended depends on the connector and cable used.

For the protective caps, the recommended torque to be applied is 12.5 kgf-cm. Applying a higher torque may damage the caps.

Connecting to the Serial Port

The TN-4500B Series has a M12 B-coded 5-pin female connector. Users can use an adapter to connect a management PC and control the device using commands through the CLI (Command-Line Interface).

Pinouts for the M12-B (5-pin) Port

PIN	CON
1	TX
2	RX
3	DSR
4	GND
5	DTR

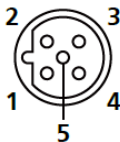

NOTE We recommend the console cable M12BMM5PF9-BK-150-IP68.

Connecting to the USB Storage Port

The TN-4500B Series has a M12 A-coded 5-pin female connector. Users can either use an adapter or the ABC-02-P-USB-M12 to connect to a PC or to import configuration files to the device.

PIN	CON
1	D-
2	5V
3	NC
4	D+
5	GND

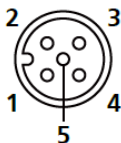

NOTE We recommend the ABC-02-P-USB-M12-CT-T USB storage for storing and load the configuration.

BSMI—限用物質含有情況標示聲明書

Declaration of the Presence Condition of the Restricted Substances Marking

設備名稱：網管交換機		型號（型式）：TN-4500B（及其系列型號）				
Equipment name		Type designation (Type)				
單元 Unit	限用物質及其化學符號					
	鉛 (Pb)	汞 (Hg)	鎘 (Cd)	六價鉻 (Cr+6)	多溴聯苯 (PBB)	多溴二苯醚 (PBDE)
外殼	○	○	○	○	○	○
印刷電路板及其電子組件	-	○	○	○	○	○
電纜/電線/連接器	-	○	○	○	○	○
機械部件-金屬	-	○	○	○	○	○
機械部件-非金屬	○	○	○	○	○	○

備考1. “超出0.1 wt %”及“超出0.01 wt %”係指限用物質之百分比含量超出百分比含量基準值。
Note 1: “Exceeding 0.1 wt %” and “exceeding 0.01 wt %” indicate that the percentage content of the restricted substance exceeds the reference percentage value of presence condition.

備考2. “○”係指該項限用物質之百分比含量未超出百分比含量基準值。
Note 2: “○” indicates that the percentage content of the restricted substance does not exceed the percentage of reference value of presence.

備考3. “-”係指該項限用物質為排除項目。
Note 3: The “-” indicates that the restricted substance corresponds to the exemption.



WARNING

為避免電磁干擾，本產品不應安裝或使用於住宅環境。

製造商資訊：

Moxa 四零四科技股份有限公司

+886-3-2737575

桃園市八德區和平路 1111 號

產品型號：

TN-4508B-CT-T
TN-4512B-CT-T
TN-4512B-8P-4G-CT-T
TN-4516B-CT-T
TN-4516B-8G-CT-T
TN-4516B-8P-4G-4GP-CT-T
TN-4516B-8P-4GP-4GBP-CT-T
TN-4520B-12P-4G-4GP-CT-T
TN-4520B-12P-4GP-4GBP-CT-T
TN-4528B-20P-4G-4GP-CT-T
TN-4528B-20P-4GP-4GBP-CT-T